

HTNSP Hex Threaded Nylon SturdiPost Metric

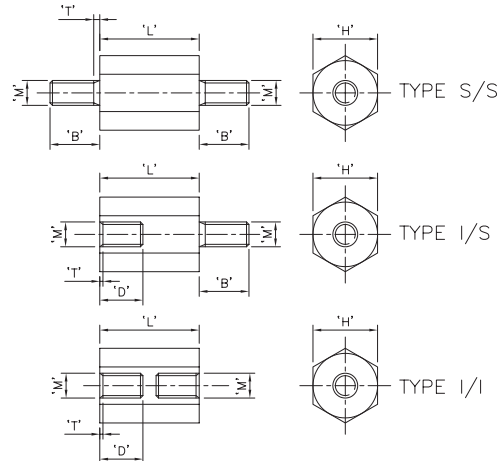
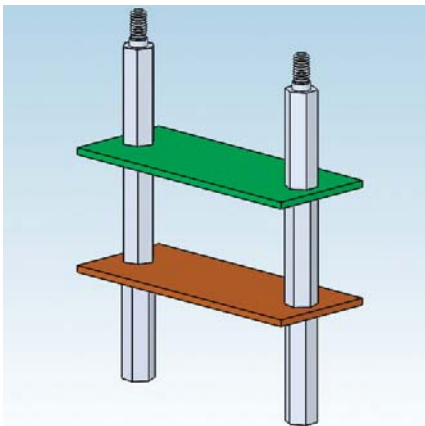

Features

- For use where high mechanical strength is required
- Provides sturdy, insulated spacing for high power electronic applications
- Metal insert and/or stud permanently molded in nylon spacer

Part Number	HTNSP- Base P/N	M2- Thread	6.4- "H"	16.0- "L"	I/S Type
-------------	--------------------	---------------	-------------	--------------	-------------

HTNSP		Standard Pack: 100 per bag		All dimensions in mm.		
Mat'l: Nylon 6/6, RMS-139. Inserts: Brass, Color: Natural	Thread	Standoff Height "L" Parts available in 1mm increments.	"H" Body Diameter	"B" Stud Length	"D" Insert Depth	"T"
HTNSP-M2-6.4-L-STYLE	M2	15.0 - 50.0	6.4	6.0	6.0	0.60
HTNSP-M2.5-6.4-L-STYLE	M2.5	15.0 - 50.0	6.4	6.0	6.0	0.68
HTNSP-M3-6.4-L-STYLE	M3	15.0 - 50.0	6.4	6.0	6.0	0.75
HTNSP-M4-8.0-L-STYLE	M4	15.0 - 75.0	8.0	6.0	6.0	1.05
HTNSP-M5-9.5-L-STYLE	M5	20.0 - 75.0	9.5	10.0	10.0	1.20
HTNSP-M6-12.7-L-STYLE	M6	25.0 - 75.0	12.7	12.7	12.7	1.50

Available by special order only. 1,000 piece minimum.

Unthreaded length = 1.5 pitch max.

MTNSP Micro Threaded Nylon SturdiPost Metric

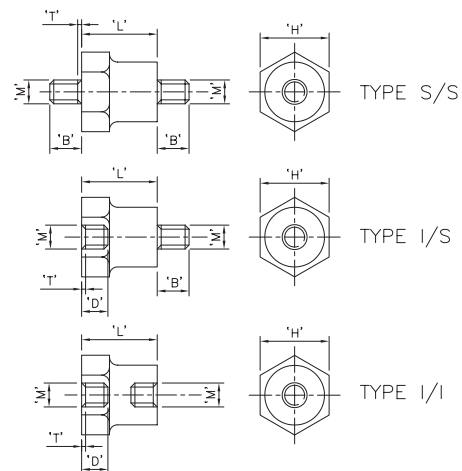
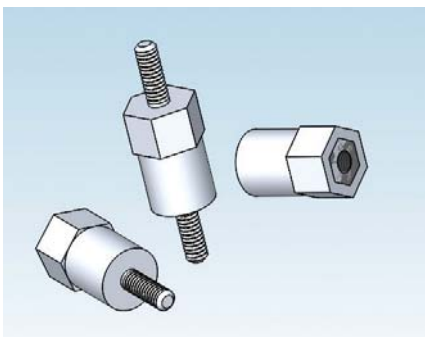

Features

- For use where high mechanical strength is required
- Provides sturdy, insulated spacing for high power electronic applications
- Metal insert and/or stud permanently molded in nylon spacer

Part Number	MTNSP- Base P/N	M2.5- Thread	6- "H"	10.0- "L"	I/S Type
-------------	--------------------	-----------------	-----------	--------------	-------------

MTNSP		Standard Pack: 100 per bag		All dimensions in mm.		
Mat'l: Nylon 6/6, RMS-133. Inserts: Brass, Color: Natural	Thread	Standoff Height "L" Parts available in 1mm increments.	"H" Body Diameter	"B" Stud Length	"D" Insert Depth	"T"
MTNSP-M2.5-6-L-S/S	M2.5	4.0 - 12.0	6.0	6.0	-	-
MTNSP-M2.5-6-L-I/S	M2.5	7.0 - 12.0	6.0	6.0	4.0	0.68
MTNSP-M2.5-6-L-I/I	M2.5	9.0 - 12.0	6.0	-	4.0	0.68
MTNSP-M3-7-L-S/S	M3	4.0 - 12.0	7.0	6.0	-	-
MTNSP-M3-7-L-I/S	M3	7.0 - 12.0	7.0	6.0	4.0	0.75
MTNSP-M3-7-L-I/I	M3	9.0 - 12.0	7.0	-	4.0	0.75

Available by special order only. 1,000 piece minimum.

Unthreaded length = 1.5 pitch max.